

## ODU Single Power Connector High Current Connector



## ODU SPC – Single Power Connector



### Applications:

- Renewable energy  
e.g. solar or wind power
- Industrial- and controlgear
- Power and emergency power supply
- Lightning technology
- Railway technology
- Labor
- Testing.

### Features:

- Single Power Connector
- Secure locking system
- Reliable connection under vibration
- Touch proof IP 2X.

The latest version of this catalog is posted on our websites:

[www.odu.de](http://www.odu.de)

[www.odu-usa.com](http://www.odu-usa.com)

[www.odu-china.com](http://www.odu-china.com)

All data and specifications subject to change without notice:

All dimensions in mm.

All pictures are illustrations.

## Table of contents

Chapter		from page	
1	Product description	5	
2	ODU SPC with push-pull locking	13	
3	ODU SPC with push-pull locking protection class IP 50 and IP 67	15	
4	Special solutions	25	
5	Accessories Tools and termination technologies Assembly instructions	29 33 37	
6	Technical information	41	
7	Part number key and inquiry form	54	

## Order information

How to find the right connector:

- Choose on page 13 the type of connector.
- Release the relevant numbers or letters into the 19 position part number (Order form see last page).
- Choose coding, housing material, insulation body material, contact surface, termination, cross section and collet system in reference to the charts on page 22, 23 and 24.
- Release the relevant numbers or letters into the 19 position part number.

## Product description



## Important issues at a glance

The new product line SPC is a combination of the proven ODU lamella contacts and a robust housing with push-pull locking.

### Advantages:

- No accidental demating because of the push-pull locking
- Power Connector
  - High voltage contact with touch proof IP 2X in unmated condition
  - Nominal current up to 300 A
  - Nominal voltage up to 1,000 V (with EMI protection on request)
- Protection class IP 50 or IP 67 in mated condition
- High number of mating cycles > 5,000
- Operation temperature: -40° up to +140° C
- High economy:
  - Economical processing because of crimp termination
  - Economical combination (single contact and housing)
  - Economical prices
  - Robust housing
- Low mating and demating forces
- Housing non-magnetic
- High chemical resistance
- For use under harsh environmental conditions
- RoHS-Conform: The connector ODU SPC meets the demands of the 2002/95/EG guideline.



## Push-pull locking principle

Pulling on the cable or on the back nut causes the locking fingers to grip tighter into the groove inside receptacle. A separation is virtually impossible.

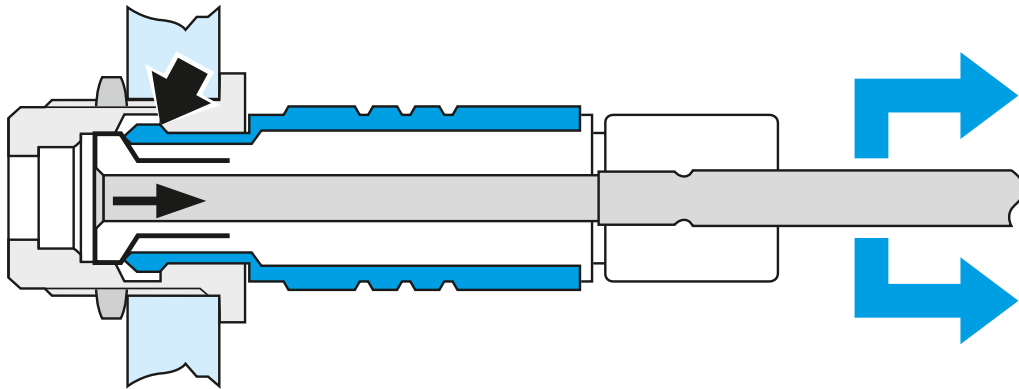

Pulling on the outer plug housing disengages the locking fingers from the receptacle groove and the connector separates easily.

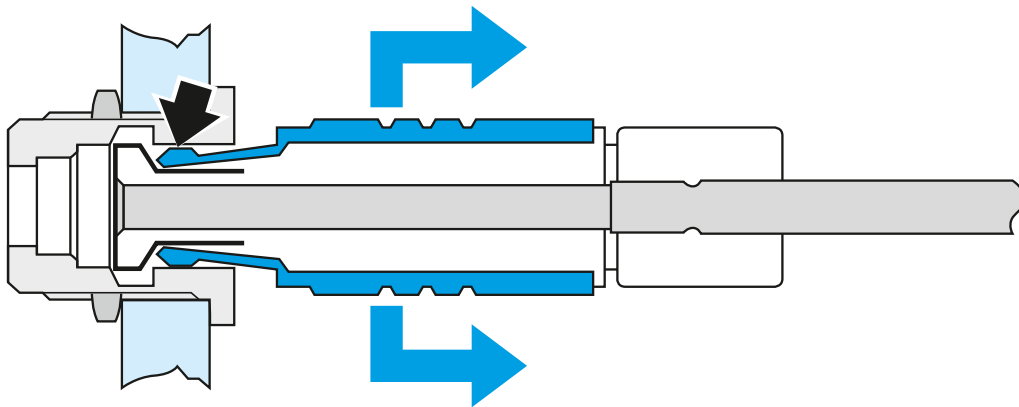

### The advantages of push-pull locking

- Quick and easy mating and locking
- Quick and easy separating
- Easy blind mating in difficult-to-reach places
- Less space required
- Definite and secure locking condition.

## Contact technology: ODU lamella contact

The lamella contact consists of a stamped contact band with lamellas which is mounted into a turned carrier. The individual lamella ridges result in a multitude of contact points that guarantee a high level of contact stability and ensure optimal conductive characteristics. The adjusted contact force ensures low insertion and removal forces, and consequently a long service life with few signs of wear.

If the contact diameter is 4 mm, for example, the ODU lamella contact results in a total of 18 contact points. Larger diameters correspondingly produce more contact points.

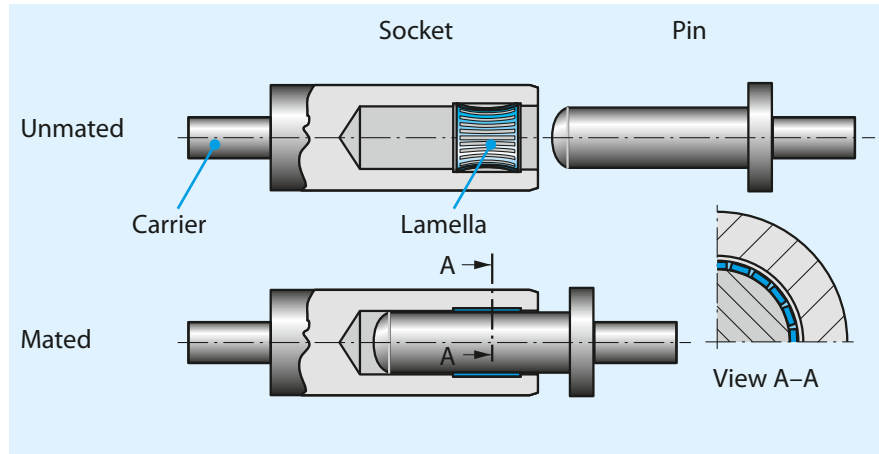

### Features / Advantages

- Low contact resistance
- Low fall of voltage
- High number of contact points
- High number of mating cycles / long product lifetime
- High ampacity
- Constant power transmission
- No loss of power.

## Construction ODU SPC

Housing made out of plastic with push-pull locking:

- Protection class IP 50 / IP 67 (in mated condition)
- Touch proof IP2X (in unmated condition)
- Mechanical and colour keying possibilities.

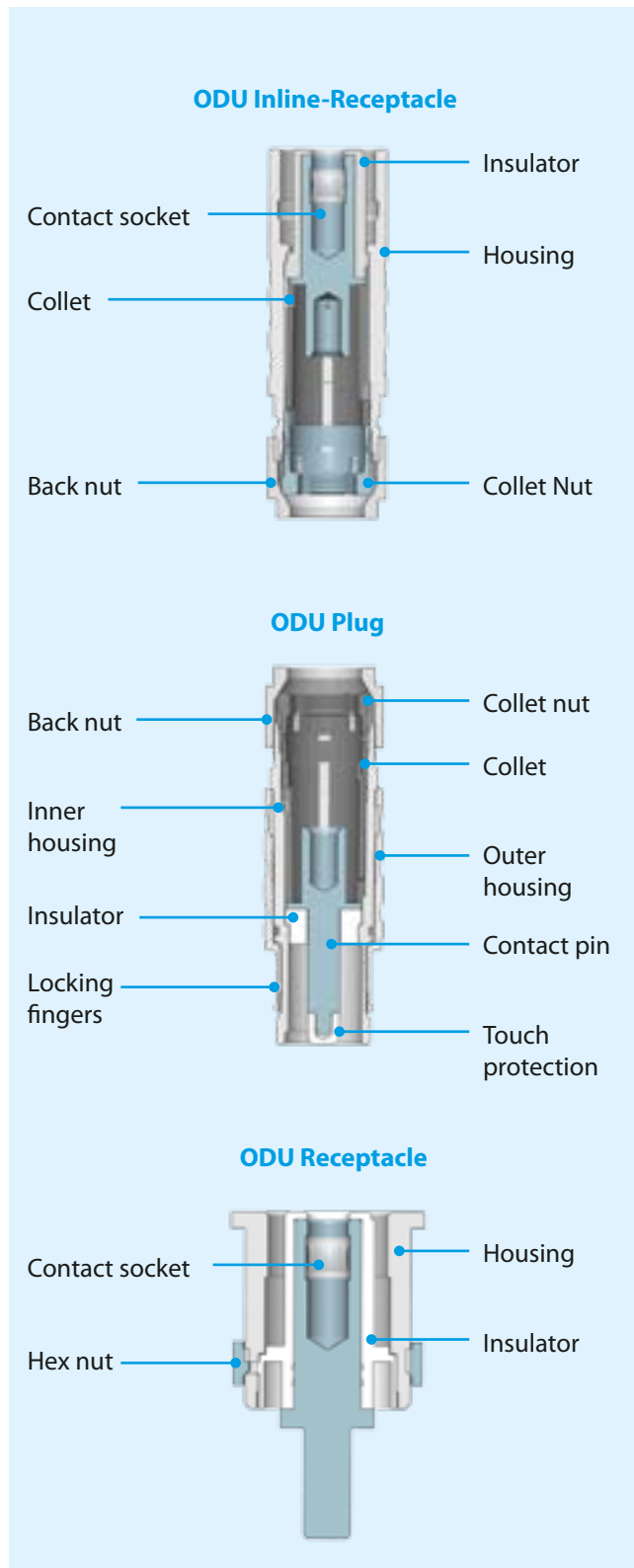

## Everything from one source – ODU the system supplier

Every connection also needs its cable. Make no compromises here when it comes to the quality of the complete connection system. ODU gives you the complete system solution from one source, with no intermediary suppliers.

Cable assembly is a very complex subject. It requires equal measures of expertise in the areas of connectors, cables and assembly. ODU meets all these requirements in full.

Benefits for the customer:

- ODU handles the **complete processing**, from procuring the cable to procuring connectors from other companies, and assembly up to individual extrusion or potting
- **No one knows our products better than we** – no one knows how our products have to be processed better than we do
- **Close cooperation and experience** with well-known cable manufacturers
- Assembly of all **standard lines**, as well as special lines such as **hybrid cable**
- Assembly of **overmolded cable** crossovers
- **100 % inspection** – systems can be used at the customer without testing.
- Various **potting options** for water-tight or vacuum-tight system
- **UL approval** (File: E333666) for cable assembly
- **Production in cleanroom** acc. EN ISO 14644-1 possible
- Production acc. **medical certification** ISO 13485:2003 + AC : 2007 possible
- **State-of-the-art production facilities** in Mühldorf (Germany), Shanghai (China), Camarillo (USA) and Sibiu (Romania).



## The part number key

No.	Description	Coding																					
			1 2 3 4 5 6 7 8 9 10 11 12 13 14 15 16 17 18 19																				
			<table border="1" style="margin-left: auto; margin-right: auto;"> <tr> <td></td><td></td><td></td><td>P</td><td></td><td></td><td>-</td><td></td><td></td><td></td><td></td><td></td><td>A</td><td></td><td></td><td></td><td>-</td><td></td><td></td><td></td> </tr> </table>				P			-						A				-			
			P			-						A				-							
1	Type	S = Plug G = Receptacle K = In-line receptacle	↑																				
2	Style	1 – 9 and A – Z	↑																				
3	Size	1, 2, 3	↑																				
4	SPC	P	↑																				
5	Coding		↑																				
6	Housing material / colour		↑																				
8	Insulator material		↑																				
9	Colour coding*		↑																				
10	Surface		↑																				
11	Termination		↑																				
12	Type	A	↑																				
13	Termination cross section (2 positions)		↑																				
14			↑																				
16	Collet system (2 positions)		↑																				
17			↑																				
18	Cable bend relief (2 positions)		↑																				
19			↑																				

\* Size 1 – 3: Colour Coding with cable bend relief

### Example

1	2	3	4	5	6	7	8	9	10	11	12	13	14	15	16	17	18	19
S	1	1	P	2	G	-	U	0	A	C	A	K	0	-	3	7	0	0

- 1 = Plug
- 2 = Style 1, IP 50 with standard back nut
- 3 = Size 1
- 4 = Product series SPC
- 5 = Coding 2
- 6 = Plastic housing in grey
- 8 = Insulator material PSU/PPSU
- 9 = No colour coding
- 10 = Surface Ag
- 11 = Crimp termination
- 12 = Plastic housing – without EMI protection
- 13/14 = Cross section 4.0mm<sup>2</sup>
- 16/17 = Collet system for cable diameter > 2.5 – 3.7 mm
- 18/19 = Without cable bend relief



## ODU SPC with push-pull locking



## Available housing sizes

### Outside diameter – Plug

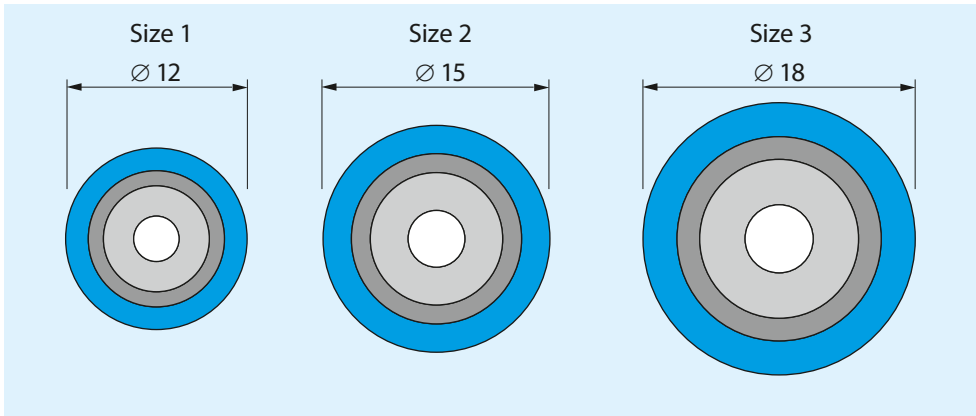

Dimensions in mm

### Technical data

Mechanical and electrical data	Size / Contact diameter		
	1 Ø 3.0 mm	2 Ø 4.0 mm	3 Ø 5.0 mm
<b>Mechanical data:</b>			
Insertion force	10 N	13 N	16 N
Withdrawal force	9 N	12 N	15 N
Draw out strength <sup>1</sup>	> 75 N	> 80 N	> 85 N
<b>Electrical data:</b>			
Nominal current <sup>2</sup>	32 A	42 A	53 A
Max. continuous current <sup>2</sup>	55 A	70 A	91 A
Surge current (period 10 ms)	5 kA	8 kA	12 kA
Rated voltage (= nominal voltage) <sup>3</sup>	1,000 V	1,000 V	1,000 V
Test voltage	4,260 V	4,260 V	4,260 V
Contact resistance	350 µΩ	300 µΩ	250 µΩ

<sup>1</sup> Connector can be used again after a accidentally demating. The datas are for the standard housing – without insert.

<sup>2</sup> Derating measurement procedure see page 42 / 43. Data derived from the derating curve.

<sup>3</sup> Tested with standing voltage with 50 Hz acc. DIN EN 61984 (VDE 0627) : 2009-11 / EN 61984 : 2009.

**ODU SPC  
with push-pull locking  
protection class IP 50 and IP 67\***



\*Explanation of protection classes see page 47.

## Straight plug



### Type

1	2	3	4	5	6	7	8	9	10	11	12	13	14	15	16	17	18	19
			P			-		0			A							

Connector type	Style		Type of back nut
S	1	IP 50 – with standard back nut	0 0
S	2	IP 50 – with back nut for cable bend relief	0 S
S	3	IP 67 – with standard back nut	0 0
S	4	IP 67 – with back nut for cable bend relief	0 S

### Size

1	2	3	4	5	6	7	8	9	10	11	12	13	14	15	16	17	18	19
			P			-		0			A							

Size	Dimensions in mm				
	L1	L2	∅ D	SW-A	SW-B
1	~ 46	~ 35	12.5	11	11
2	~ 52	~ 40	15.7	14	14
3	~ 60	~ 45	18.7	16	17

Cable bend relief must be ordered separately. See page 30.  
 Explanation of protection classes see page 47.

### Style 1 and 3

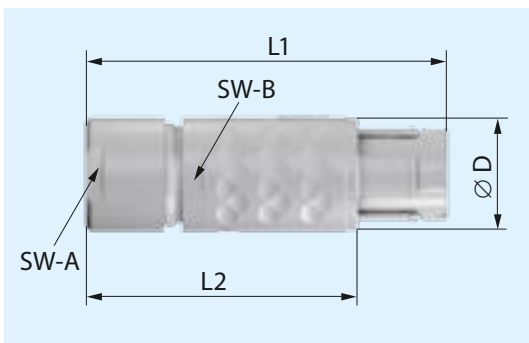

### Style 2 and 4

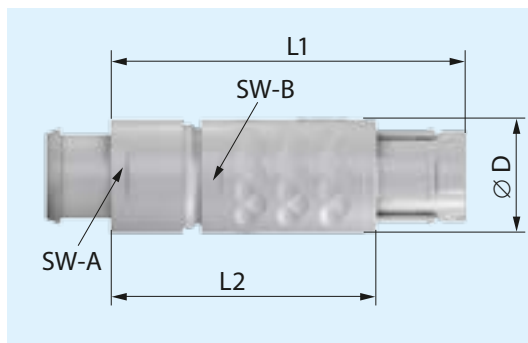
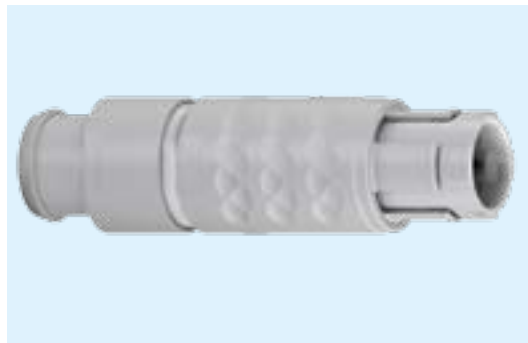

## Receptacle



### Type

1	2	3	4	5	6	7	8	9	10	11	12	13	14	15	16	17	18	19
			P			-		0			A							

Connector type	Style	
G	1	IP 50 – for installation from front of panel
G	5	IP 50 – see page 18
G	E	IP 67 – see page 19

### Size

1	2	3	4	5	6	7	8	9	10	11	12	13	14	15	16	17	18	19
			P			-		0			A							

Size	Dimensions in mm						Panel cut-out 
	L	∅ D	C	M2	M3	SW	
1	18.5	16.5	2.0	5.5	M4	16.0	SW 12.6 / ∅ 13.6
2	20.5	21.0	2.0	5.5	M5	19.0	SW 15.6 / ∅ 16.6
3	25.0	24.5	2.0	5.5	M6	24.0	SW 19.1 / ∅ 21.1

Cable bend relief must be ordered separately. See page 30.  
Explanation of protection classes see page 47.

### Style 1

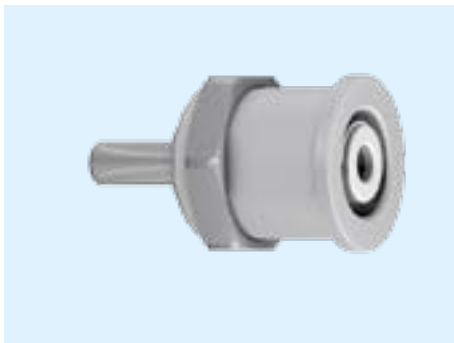

#### Technical data

- IP 50 in reference to the tightness of the end device
- Anti-rotation feature
- Minimum wall-thickness 1 mm
- Touch proof.

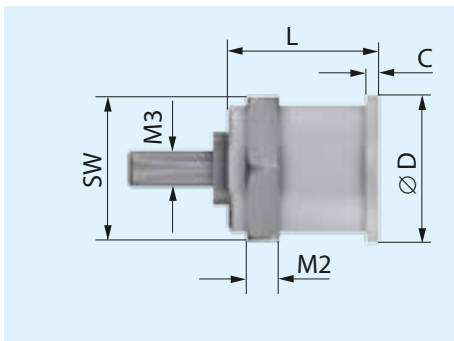

## Receptacle



### Type

1	2	3	4	5	6	7	8	9	10	11	12	13	14	15	16	17	18	19	
			P			-		0			A								

Connector type	Style	
G	1	IP 50 – see page 17
G	5	IP 50 – with continuous thread, installation from rear or front of panel, optimal distance adjustment
G	E	IP 67 – see page 19

### Size

1	2	3	4	5	6	7	8	9	10	11	12	13	14	15	16	17	18	19	
			P			-		0			A								

Size	Dimensions in mm						Panel cut-out 
	L	Ø D	M1	M2	M3	SW	
1	18.5	19.0	5.0	5.5	M4	16.0	SW 12.6 / Ø 13.6
2	20.5	21.5	5.0	5.5	M5	19.0	SW 15.6 / Ø 16.6
3	25.0	28.0	5.0	5.5	M6	24.0	SW 19.1 / Ø 21.1

Cable bend relief must be ordered separately. See page 30.  
Explanation of protection classes see page 47.

### Style 5

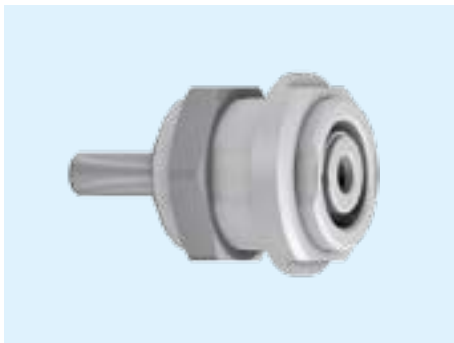

#### Technical data

- IP 50 in reference to the tightness of the end device
- Anti-rotation feature
- Minimum wall-thickness 1 mm
- Touch proof.

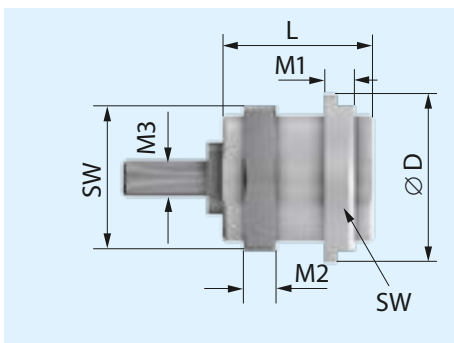

## Receptacle



### Type

1	2	3	4	5	6	7	8	9	10	11	12	13	14	15	16	17	18	19
			P			-		0			A						0	0

Connector type	Style	
G	1	IP 50 – see page 17
G	5	IP 50 – see page 18
G	E	IP 67 – for installation from front of panel

### Size

1	2	3	4	5	6	7	8	9	10	11	12	13	14	15	16	17	18	19
			P			-		0			A							

Size	Dimensions in mm							Panel cut-out 
	L	∅ D	C	M1	M2	M3	SW	
1	22.0	18.5	~6.0	~6.0	5.5	M4	16.0	SW 12.6 / ∅ 13.6
2	24.0	22.5	~6.0	~6.0	5.5	M5	19.0	SW 15.6 / ∅ 16.6
3	28.5	26.5	~6.0	~6.0	5.5	M6	24.0	SW 19.1 / ∅ 21.1

Explanation of protection classes see page 47.

### Style E



#### Technical data

- IP 67 in **mated** condition
- IP 50 in **unmated** condition and in reference to the tightness of the end device
- Anti-rotation feature
- Minimum wall-thickness 1 mm
- Touch proof.

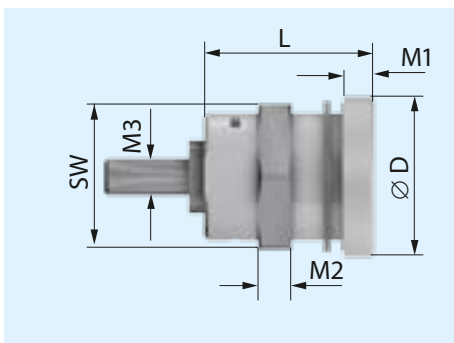

**In-line receptacle**



**Type**

1	2	3	4	5	6	7	8	9	10	11	12	13	14	15	16	17	18	19
			P	S	-	0					A							

Connector type	Style		Type of back nut
K	1	IP 50 – with standard back nut	0 0
K	2	IP 50 – with back nut for cable bend relief	0 S
K	3	IP 67 – see page 21	0 0
K	4	IP 67 – see page 21	0 S

**Size**

1	2	3	4	5	6	7	8	9	10	11	12	13	14	15	16	17	18	19
			P	S	-	0					A							

Size	Dimensions in mm			
	L	∅ D	SW-A	SW-B
1	~ 46	12.5	11	11
2	~ 52	15.7	14	14
3	~ 60	18.7	16	17

Cable bend relief must be ordered separately. See page 30.  
 Explanation of protection classes see page 47.  
 Note: Standard colour is black – other colours on request!

**Style 1**

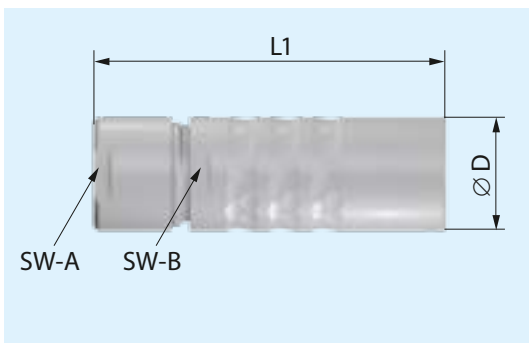

**Style 2**

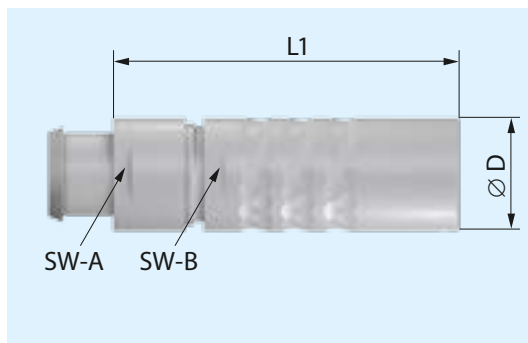
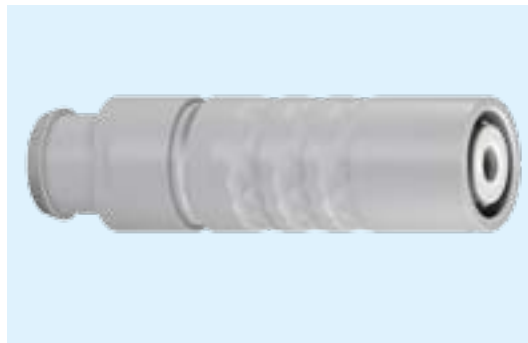

**In-line receptacle**



**Type**

1	2	3	4	5	6	7	8	9	10	11	12	13	14	15	16	17	18	19
			P	S	-	0					A							

**Size**

1	2	3	4	5	6	7	8	9	10	11	12	13	14	15	16	17	18	19
			P	S	-	0					A							

Connector type	Style		Type of back nut
K	1	IP 50 – see page 20	0 0
K	2	IP 50 – see page 20	0 S
K	3	IP 67 – with standard back nut	0 0
K	4	IP 67 – with back nut for cable bend relief	0 S

Size	Dimensions in mm			
	L1	∅ D	SW-A	SW-B
1	~ 46	16.2	11	11
2	~ 52	19.8	14	14
3	~ 60	23.0	16	17

Cable bend relief must be ordered separately. See page 30.  
 Explanation of protection classes see page 47.  
 Note: Standard colour is black – other colours on request!

**Style 3**



**Style 4**

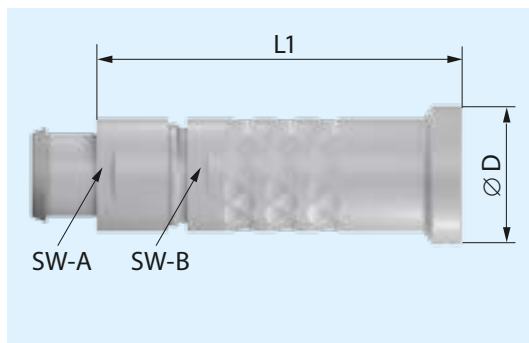
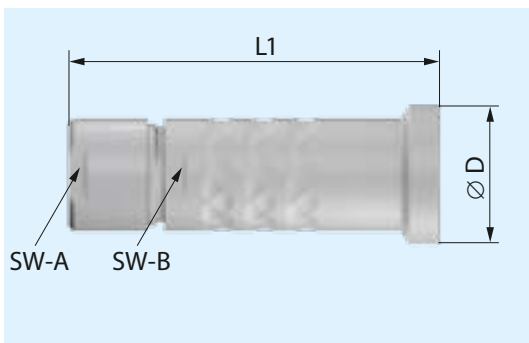
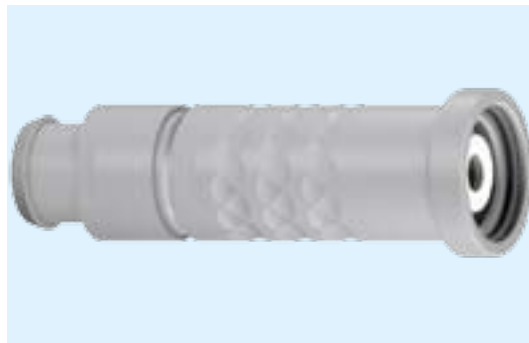

### Coding

1	2	3	4	5	6	7	8	9	10	11	12	13	14	15	16	17	18	19
			P		-			0			A							

Coding	Receptacle front view	Size		
		1	2	3
1		•	•	•
2		•		•
9		•		•

### Housing material



1	2	3	4	5	6	7	8	9	10	11	12	13	14	15	16	17	18	19
			P		-			0			A							

Housing material	Housing material
G	Plastic, grey (similar RAL 7035)
S	Plastic, black (similar RAL 9004)
W	Plastic, white (similar RAL 9002), on request

### Insulator material

1	2	3	4	5	6	7	8	9	10	11	12	13	14	15	16	17	18	19
			P					0			A							

Material insulation body	Material
U	PSU / PPSU (autoclaveable)

### Contact surface

1	2	3	4	5	6	7	8	9	10	11	12	13	14	15	16	17	18	19
			P					0			A							

Contact surface	Contact surface
A	Galv. Ag (standard)
B	Galv. Au (updated resistance)

Explanation of protection classes see page 47

### Termination

### Cross section



1	2	3	4	5	6	7	8	9	10	11	12	13	14	15	16	17	18	19	
			P			-		0		A									

1	2	3	4	5	6	7	8	9	10	11	12	13	14	15	16	17	18	19	
			P			-		0		A				-					

	Termination	Connector type		
		Plug	Receptacle	In-line receptacle
Crimp	C	● Standard	●	● Standard
Solder	L	●	●	●
Screw	S		● Standard	

Cross section		Cross section	Size		
mm <sup>2</sup>	AWG		1	2	3
4.0	-	K 0	●		
6.0	10	L 0		●	
10.0	8	N 0			●

Biggest possible cross section is stated. This cross-section depends on the cable diameter under consideration of the collet system. Other cross sections on request!

Explanation of protection classes see page 47.

## Collet system

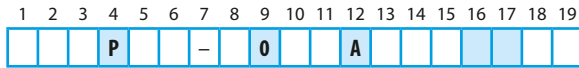

Cable diameter mm	Size			Collet system
	1	2	3	
> 1.5 – 2.5	●			2 5
> 2.5 – 3.7	●			3 7
> 3.1 – 4.5		●		4 5
> 3.7 – 4.9	●			4 9
> 4.6 – 6.0		●	●	6 0
> 4.9 – 6.0	●			6 0
> 6.1 – 7.5		●	●	7 5
> 7.6 – 9.0		●	●	9 0
> 9.1 – 10.5			●	0 2

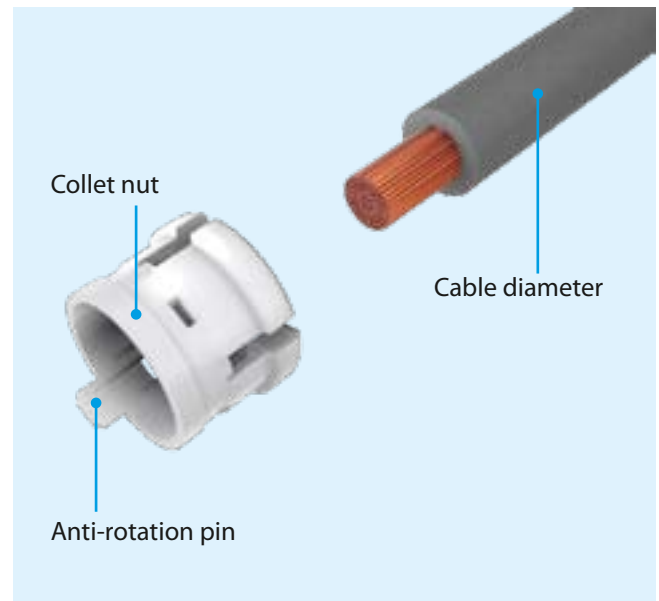

## Special solutions



## Special solutions

ODU as specialist in customized solutions has all main competences under one roof. Development, our own tool shop, stamping, moulding, surface plating, manufacturing of complete assembly machines, cable assembly, etc. With all these possibilities we are able to offer "custom tailored" solutions for our customers.

When do we actively pursue custom specific solutions? Are development effort, tool making and production costs in an acceptably proportion to lot size and unit price? Our know-how makes it possible to give you fast and competent information.

Here are some examples how a special solution may look:

### ODU SPC with metal housing and bayonet-locking

- Robust zinc-die-casting housing
- Effective power 300 A / 1,000V
- Easy mating and demating because of bayonet-locking
- High resistance against chemical and environmental influences.



### ODU SPC with plastic housing and snap-in locking

- Economical plastic housing
- Effective power 50 A / 400V
- Easy to assembly
- Housing available in custom colour.



### ODU SPC High Current with bayonet-locking

- Robust plastic housing
- Effective power 550 A / 1,000V
- Bayonet- and optional secondary locking
- Colour coding acc. to DIN 0293-308 possible
- Optional: Termination technology for alu cable.





**ODU SPC series 329**

- Current up to 400 A
- Voltage up to 380 V
- Robust housing
- Bajonett locking.



**ODU SPC with EMI Protection**

With metalized inner housing.

Metalized inner housing

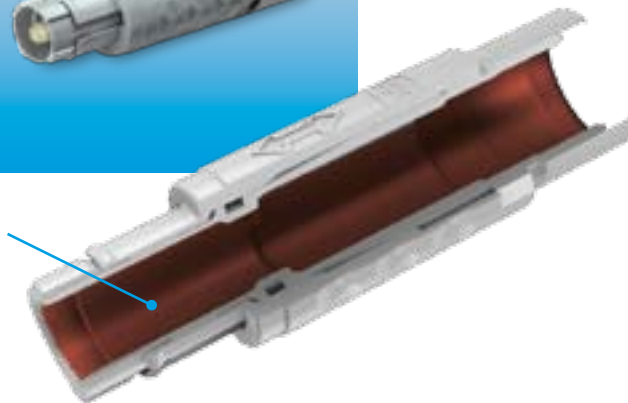



## Accessories, Tools and termination technology Assembly Instructions



## Silicone cable bend relief

Because of different raw materials the colours may slightly differ from RAL numbers.

Temperature range:  
Silicone: -50°C bis +200°C,  
Short-term up to +230°C

Autoclaveable

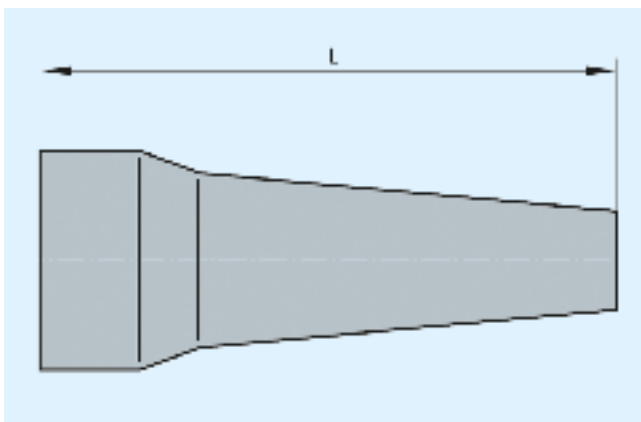

Size	Part number	Dim. L mm	Cable outer dimension	
			Min. mm	Max. mm
1	701 023 ... 965 025	30	> 2.5	3.0
	701 023 ... 965 030	30	> 3.0	3.5
	701 023 ... 965 035	30	> 3.5	4.0
	701 023 ... 965 040	30	> 4.0	5.0
	701 023 ... 965 050	30	> 5.0	6.0
2	702 023 ... 965 025	36	> 2.5	3.0
	702 023 ... 965 030	36	> 3.0	3.5
	702 023 ... 965 035	36	> 3.5	4.0
	702 023 ... 965 040	36	> 4.0	5.0
	702 023 ... 965 050	36	> 5.0	6.0
	702 023 ... 965 060	36	> 6.0	7.0
	702 023 ... 965 070	36	> 7.0	8.0
	702 023 ... 965 080	36	> 8.0	9.0
3	703 023 ... 965 040	42	> 4.0	5.0
	703 023 ... 965 050	42	> 5.0	6.0
	703 023 ... 965 060	42	> 6.0	7.0
	703 023 ... 965 070	42	> 7.0	8.0
	703 023 ... 965 080	42	> 8.0	9.0
	703 023 ... 965 090	42	> 9.0	10.0
	703 023 ... 965 100	42	> 10.0	10.5

Colour code	Colour	RAL-Nr. similar
202	Red	3020
203	White	9010
204	Yellow	1016
205	Green	6029
206	Blue	5002
207	Grey	7005
208	Black	9005

**Protective covers**

**Fasten with loop – style 1**

Protection class IP 50  
Protection class IP 67 with receptacle style E

Size	Part number	Dimensions in mm					
		A	B	C	D	∅ B	∅ E
1	K01 097 006 933 ...	7.8	18.80	15.1	75	17	10
2	K02 097 006 933 ...	8.1	19.05	15.1	85	20	13
3	K03 097 006 933 ...	10.3	19.70	16.1	100	25	16

↑ Please register desired colour of cover and lanyard material.

	Code	Material lanyard	Colour
	003	Polyamid	White
	008	Polyamid	Black
	103	Stainless steel	White
	108	Stainless steel	Black

**Fasten with solder lug – style 2**

Protection class IP 50  
Protection class IP 67 with receptacle style E

Size	Part number	Dimensions in mm				
		A	B	C	D	∅ B
1	K01 097 006 933 ...	7.8	18.80	15.1	75	17
2	K02 097 006 933 ...	8.1	19.05	15.1	85	20
3	K03 097 006 933 ...	10.3	19.70	16.0	100	25

↑ Please register desired colour of cover and lanyard material.

	Code	Material lanyard	Colour
	203	Polyamid	White
	208	Polyamid	Black
	303	Stainless steel	White
	308	Stainless steel	Black

**Style 1**

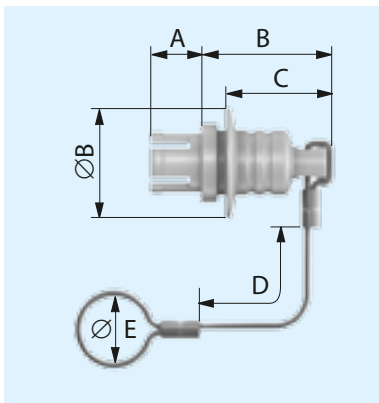
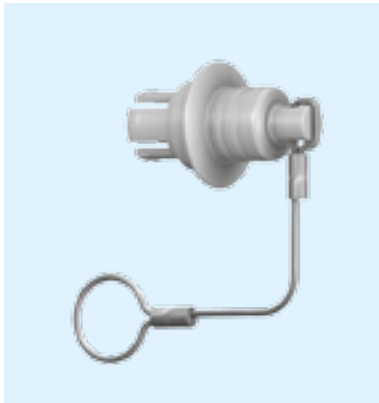

**Style 2**

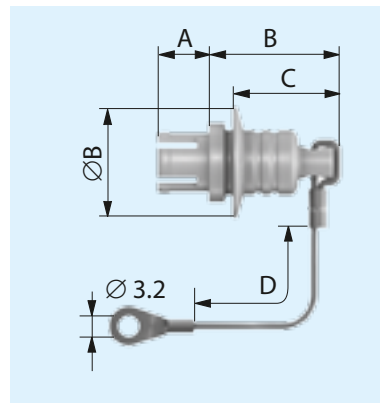
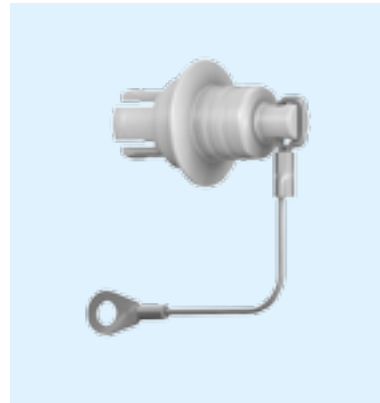

## Termination set for screw termination

### For receptacle style G1, G5 and GE

Thread	Part number
M4	117 000 000 000 001
M5	117 000 000 000 002
M6	117 000 000 000 003

### Torques

Connection thread	Torque
	Max. in Nm
M2	0.2
M3	0.5
M4	1.2
M5	2.0
M6	3.0
M8	6.0
M10	10.0
M12	16.0
M14	22.0
M16	30.0
M18	40.0
M20	50.0

Max. torque for solid threaded stud and brass contact material

### Installation

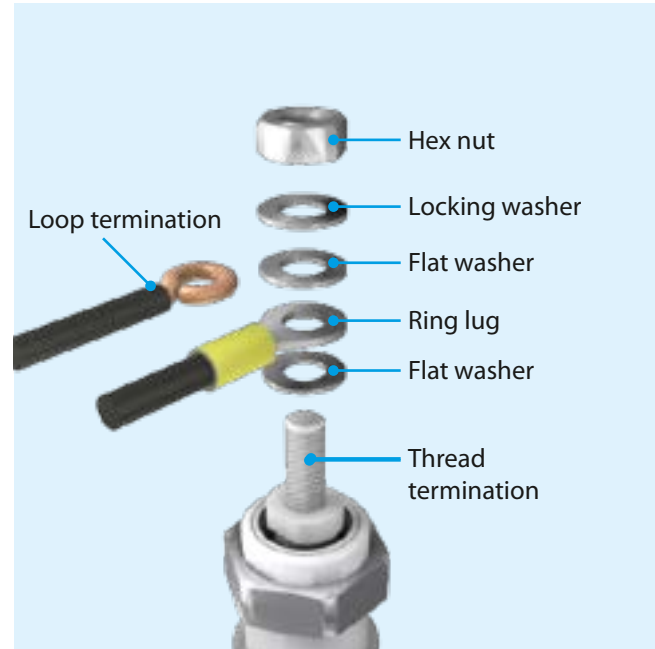

## Tools and terminations technologies



## Termination technologies

The three following termination technologies are possible for the ODU single contacts:

- Soldering
- Screwing
- Crimping

### Solder termination

Soldering uses a melted added metal (solder), whose melting temperature is less than that of the base metals to be connected, in order to connect two metallic materials. In contrast to crimping, the wire to be soldered can also be considerably smaller than the intended solder hole. Please note: avoid undue temperature increases in sockets.

### Screw termination

This method of terminating cables is usually done using cable lugs with serrated washers, flat washers and nuts. Washers and nuts are included in the delivery as standard (you will find corresponding assembly sets on page 32).

### Crimp termination

The processing of contacts by crimping in order to produce connection lines results in a permanent, corrosion-free and securely contacted connection. Even those who are not experts can produce this time-saving termination.

The cold pressing operation (crimping) compresses the conductor and contact material at the pressing points to the extent that a gas-tight connection results that is tight with respect to the conductor material.

Crimping is possible on the smallest cross-sections as well as on large ones. The 8-point crimpers are advantageously chosen for smaller cross-sections (0.5 – 2.5 mm<sup>2</sup>) while hexagonal crimpers are chosen for the larger cross-sections. The crimping's width across corners is no larger than the original diameter. This process does not damage the line's insulation, which can be run up to the contact end.

For flawless crimping, it is absolutely essential that the bore diameter be matched exactly to the cable. Flawless crimping of our contacts can only be guaranteed when the crimping tools recommended by ODU are used. In order to advise you, we will need to know your cable type and the cable cross-section – a sample with datasheet is particularly helpful.

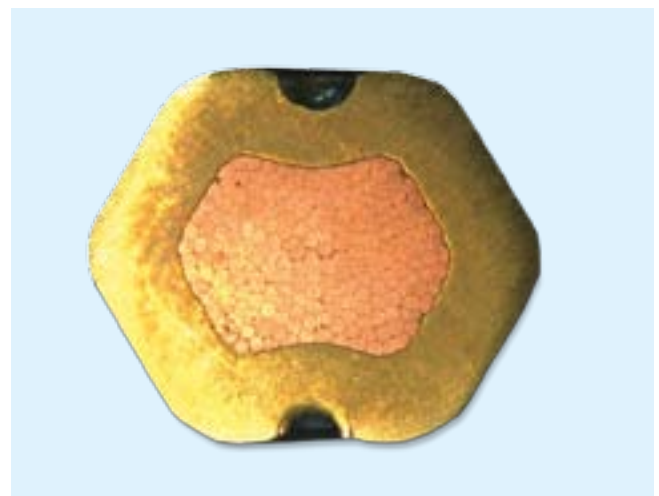

Cross-section of a hexagonal crimping.

## Tools

The crimping tools and the associated crimping inserts are designed for the forces necessary for the pressing operation, and are provided with a safeguard to prevent the crimper from opening prematurely.

Opening is only possible after the pressing has been completed with the necessary pressure.



**Hexagonal crimping tool**  
for cross-sections 4.0 mm<sup>2</sup> and 6.0 mm<sup>2</sup>.  
Order no. 080.000.011.000.000



**Hydraulic hexagonal crimping tool**  
for cross-section 10.0 mm<sup>2</sup>.  
Crimp tong: Order no. 080.000.026.000.000  
Crimp insert: Order no. 080.000.026.110.000

## Spanner wrench

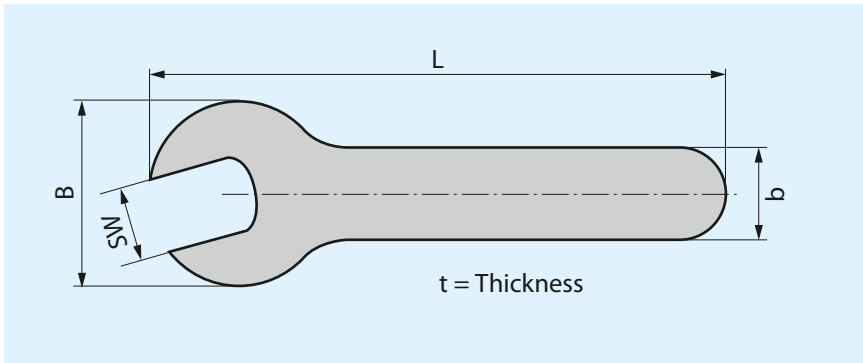

Part number	Dimensions in mm				
	SW	t	B	L	b
598.700.001.003.000	12	2.5	24.5	115	10.0
598.700.001.004.000	13	2.5	30.5	98	16.5
598.700.001.005.000	14	2.5	30.5	98	16.5
598.700.001.007.000	16	3.0	35.5	145	15.0
598.700.001.008.000	17	3.0	35.5	145	15.0
598.700.001.013.000	19	3.0	42.0	172	16.0
598.700.001.014.000	24	3.0	54.0	119	23.5

## Assembly instructions



## Assembly instructions

### Assembly of version with protection class IP 50 and IP 67

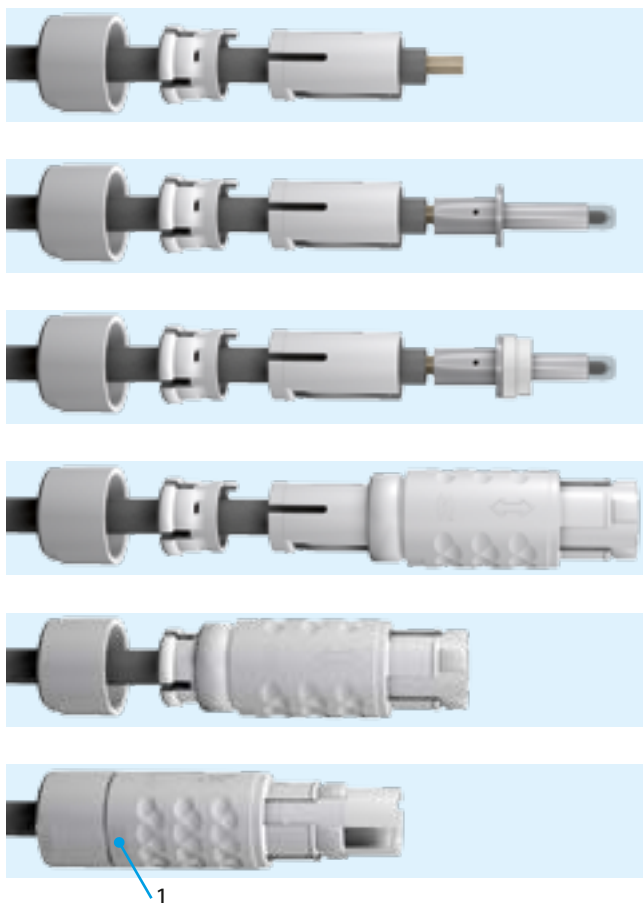
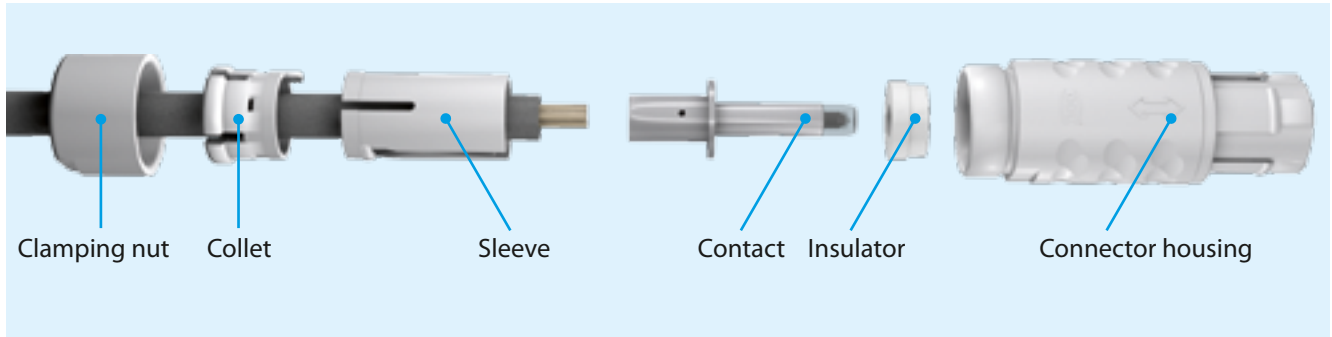

1. Slide the clamping nut, collet and sleeve on to the stripped cable.
2. Crimp or solder the wire to the contact.
3. Slide the insulator on to the contact.
4. First slide the sleeve up to the contact.
5. Slide the sleeve and collet into the connector housing (observe the position of the guide in the connector housing).
6. Screw the clamping nut on to the assembled connector, hold it against the surface (1) and use the ODU open-end wrench (see page 36) to tighten it. If necessary, secure the screw thread with adhesive.

Recommended adhesive:  
[Scotchweld, ODU order no. 890.204.000.030.025](#)  
 Recommended cleaning agent:  
[Isopropyl alcohol](#)

If adhesives that have not been released are used, cracks may appear after some time. Use only the specified adhesive.

**Stripping lengths for solder and crimp termination**

The following table is intended to simplify the assembly. It contains guideline figures for preparing the cable as far as the cable stripping lengths are concerned.

Size	1	2	3
A	7	7	10

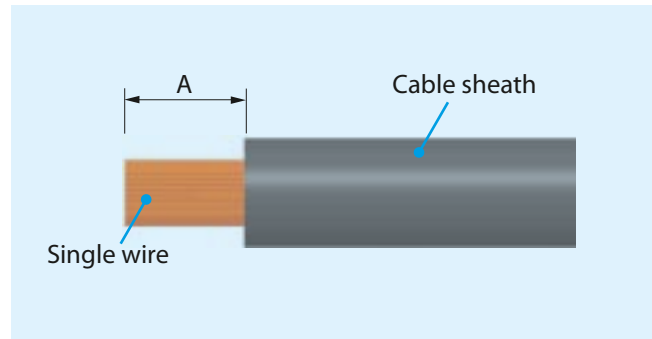

**Tightening torques for the back nuts**

Size	1	2	3
Tightening torque	0.5 Nm	0.5 Nm	0.7 Nm

1 Nm = 8.85 inch-pounds



## Technical Information



## Basic principles of current carrying capacity

### Derating measurement procedure (DIN EN 60512-5-2:2002)

#### Structure of the basis current carrying capacity curve

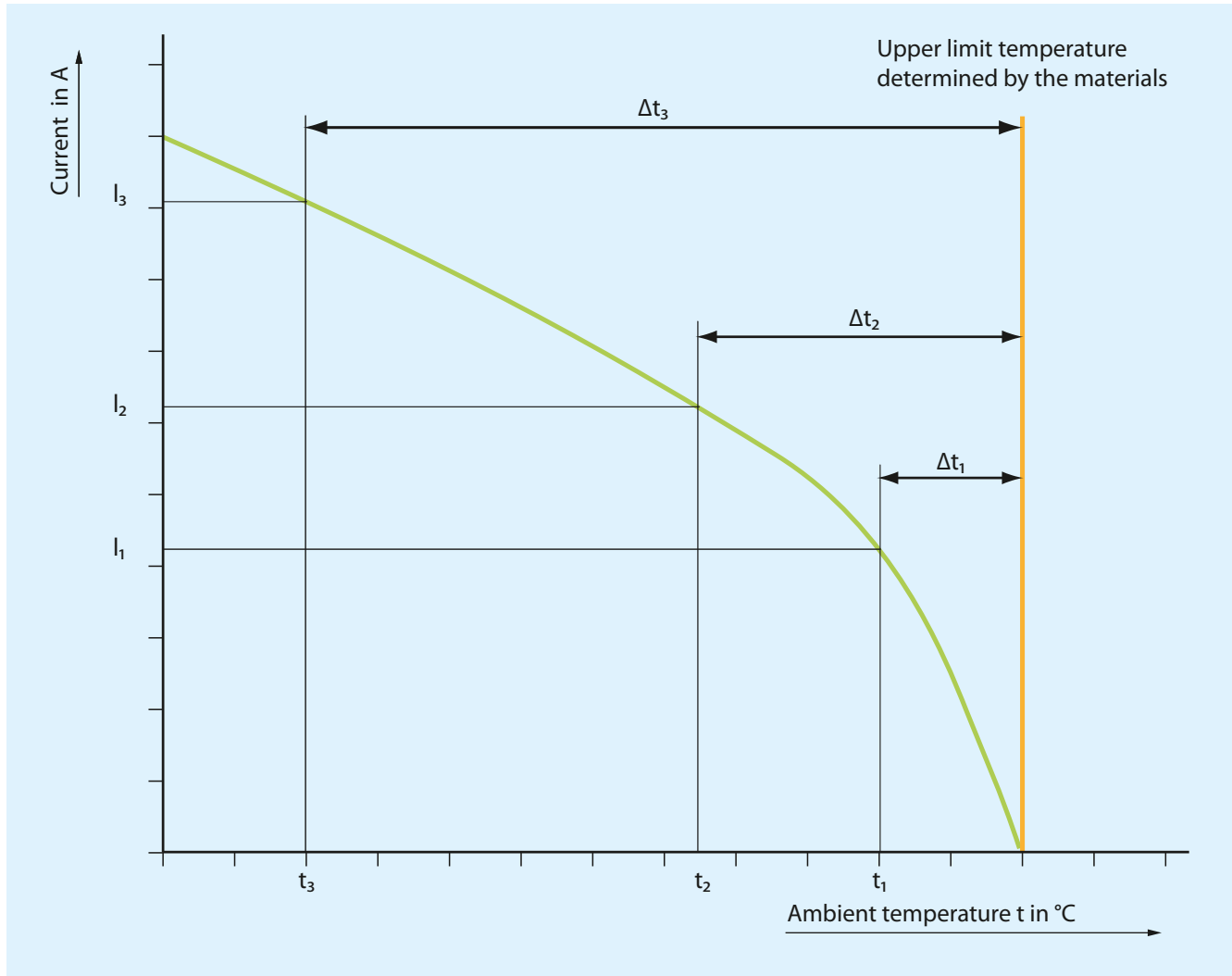

A connector's current carrying capacity is determined by measurement. The self-heating and ambient temperature are taken into account when determining the current carrying capacity, which is limited by the thermal properties of the contact materials used; the upper limit temperature of these materials should not be exceeded.

The relationship between current, the temperature increase caused as a result of the power dissipation at the contact resistor, and the ambient temperature is depicted in a curve. The curve is drawn in a linear coordinate system with the current  $I$  as the ordinate and the temperature  $t$

as the abscissa. The upper limit temperature is shown as a vertical straight line. The corrected current carrying capacity curve (derating curve) can be derived from the basis curve. To accomplish this, the measured curve is reduced by the derating factor 0.8 in order to eliminate variances, measurement errors, or the like in the test results.

In three measurements, the self-heating ( $\Delta t$ ) is determined at different currents on at least three connectors and the points determined in this process are connected to form a parabolic basis curve.

## Current carrying capacity diagram

### Capacity of the connection\*

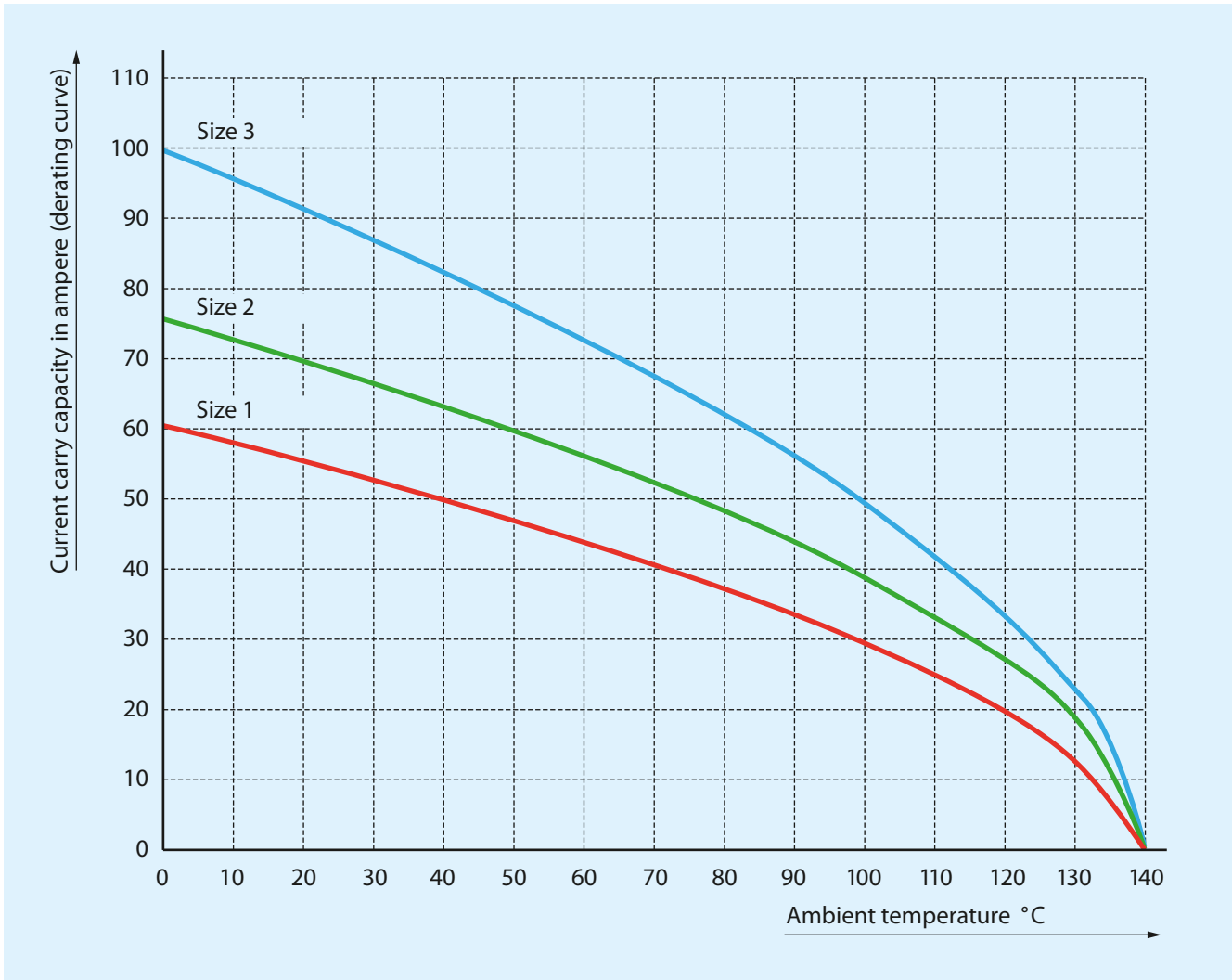

\*Tested with the stipulated termination cross-section (see page 23).

### Housing materials /surfaces

### Material insulator (V listed)

Component part	Material	Surface
Housing	PEI	
Housing (shielded)	PEI	chem. Ni
Back nut	PEI	
Collet nut	PA / PSU / PEI	
Cover	PEI	
Nut receptacle	Cu-alloy	Ni
Contacts	Cu-alloy	Ag or Au
Contact element	CuBe-alloy	Ag or Au

Attribute	Norm	Unit	PSU
Dialectric strenght	DIN 53481 ASTM D-149	kV / mm	42
Operating temperature	—	°C	-40 /+160
Flammability rating	UL-94	—	V-0
Creeping distance according to CTI	IEC 60112	V	175

## Information for the correct handling

### Failure mating force of the housing according IEC 60512-13-5

	Size 1	Size 2	Size 3
Failure mating force	> 40 N	> 40 N	> 50 N

**Not to be inserted when under load (live)**  
acc. to VDE 0627 (DIN EN 61984)

## Sterilizability

### Autoclave

The connectors in the ODU SPC series have been tested for 200 autoclave cycles according to the sterilization curve below. The standard version of ODU SPC is autoclaveable.

### Gamma Radiation

4 cycles à 25 k Gray

### E-Beam

4 cycles à 25 k Gray

For additional sterilization methods, please contact our technical team.

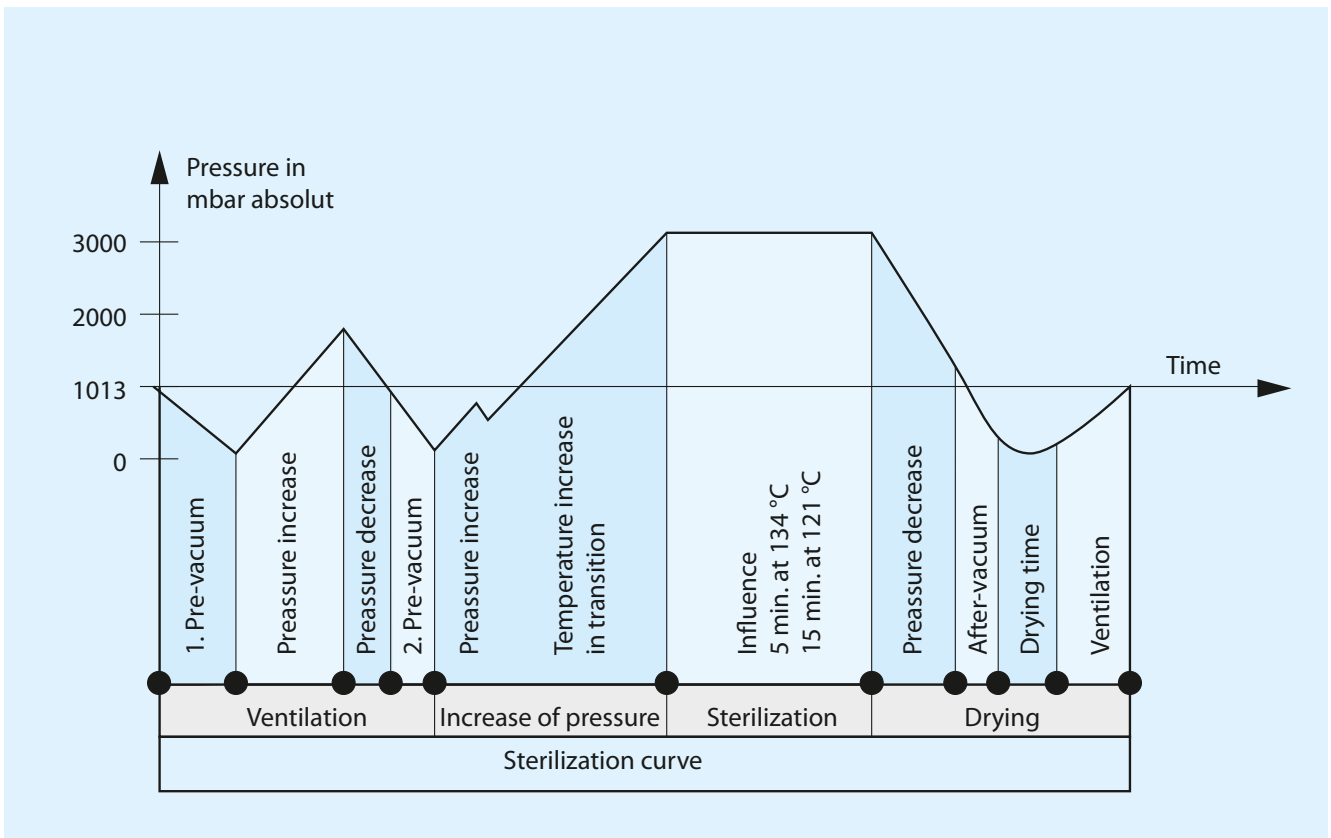

## International Protecting (IP) Classes DIN EN 60529 (respectively IEC 529 /VDE 0470 T1)

The housing and the locking system of the ODU SPC protect the contacts against outside mechanical influence, such as impact shocks, impurities, dust, unintended contact and penetration of moisture, waster or other liquids (coolants, oils, etc.)

Protection classification is indicated with the letters **IP** and two numbers.

To achieve leak tightness at the cable gland, the sealing system must be adapted to the cable and the cable must be smooth, cylindrical and grooveless.

If coordination to the cable is not possible, the cable area can also be potted.

Code letters (international protection)		First index figure (foreign bodies protection)	Second index figure (water protection)	
<b>IP</b>		<b>6</b>	<b>8</b>	
Index	Degree of protection		Index	Degree of protection
<b>0</b>		No protection against accidental contact, no protection against intrusion of solid foreign bodies	<b>0</b>	No protection against water
<b>1</b>		Protection against contact with any large area by hand and against large solid foreign bodies with $\varnothing > 50$ mm	<b>1</b>	Protection against vertical water drips
<b>2</b>		Protection against contact with the fingers, protection against large solid foreign bodies with $\varnothing > 12$ mm	<b>2</b>	Protection against water drips (up to a 15° angle)
<b>3</b>		Protection against tools, wires or similar objects with $\varnothing > 2.5$ mm. Protection against small foreign solid bodies with $\varnothing > 2.5$ mm	<b>3</b>	Protection against diagonal water drips (up to a 60° angle)
<b>4</b>		As 3 however $\varnothing > 1$ mm	<b>4</b>	Protection against splashed water from all directions
<b>5</b>		Full protection against contact. Protection against interior detrimental dust deposition	<b>5</b>	Protection against water spray from all directions
<b>6</b>		Total protection against contact. Protection against intrusion of dust	<b>6</b>	Protection against temporary flooding
			<b>7</b>	Protection against temporary immersion
			<b>8</b>	Protection against water pressure

In accordance with DIN VDE 0470, DIN EN 60 529, IEC 529  
Source: ZVEI = German Association of the Electrotechnical and Electronic Industry e.V.

## Conversions AWG – cross section (AWG = American Wire Gauge)

The AWG system describes the cross section of a wire using a gauge number for every 26% increase in conductor cross section. With larger wire diameters, the AWG gauge numbers decrease; as the wire sizes increase, the AWG gauge numbers decrease. **This is only valid for solid conductors.**

Most wires are made with **stranded conductors**. Compared to solid conductors stranded wires offer higher durability, higher flexibility and better performance under bending and vibration.

Stranded wires are made from wires with smaller gauge sizes (higher AWG gauge number). The AWG gauge number of the stranded wire is equal to that of a solid conductor of the same size wire. The cross section of the stranded conductor is the sum of cross sections of the single conductors. For example, a AWG-20 stranded wire of 7 AWG-28 conductors has a cross section of 0.563 mm<sup>2</sup>; an AWG-20 stranded wire with 19 AWG-32 conductors has a cross section of 0.616 mm<sup>2</sup>.

Conversion table AWG/mm<sup>2</sup>

Circular wire					
AWG	Diameter		Cross section mm <sup>2</sup>	Weight kg/km	Max. resistance Ω/km
	Inch	mm			
10 (1)	0.1020	2.5900	5.2700	47.000	3.45
10 (37/26)	1.1090	2.7500	4.5300	43.600	4.13
12 (1)	0.0808	2.0500	3.3100	29.500	5.45
12 (19/25)	0.0895	2.2500	3.0800	28.600	6.14
12 (37/28)	0.0858	2.1800	2.9700	26.300	6.36
14 (1)	0.0641	1.6300	2.0800	18.500	8.79
14 (19/27)	0.0670	1.7000	1.9400	18.000	9.94
14 (37/30)	0.0673	1.7100	1.8700	17.400	10.50
16 (1)	0.0508	1.2900	1.3100	11.600	13.94
16 (19/29)	0.0551	1.4000	1.2300	11.000	15.70
18 (1)	0.0403	1.0200	0.8200	7.320	22.18
18 (19/30)	0.0480	1.2200	0.9600	8.840	20.40
20 (1)	0.0320	0.8130	0.5200	4.610	35.10
20 (7/28)	0.0366	0.9300	0.5600	5.150	34.10
20 (19/32)	0.0384	0.9800	0.6200	5.450	32.00
22 (1)	0.0252	0.6400	0.3240	2.890	57.70
22 (7/30)	0.0288	0.7310	0.3540	3.240	54.80
22 (19/34)	0.0307	0.7800	0.3820	3.410	51.80
24 (1)	0.0197	0.5000	0.1960	1.830	91.20
24 (7/32)	0.0230	0.5850	0.2270	2.080	86.00
24 (19/36)	0.0252	0.6400	0.2400	2.160	83.30
26 (1)	0.1570	0.4000	0.1220	1.140	147.00
26 (7/34)	0.0189	0.4800	0.1400	1.290	140.00
26 (19/38)	0.0192	0.4870	0.1500	1.400	131.00
28 (1)	0.0126	0.3200	0.0800	0.716	231.00
28 (7/36)	0.0150	0.3810	0.0890	0.813	224.00
28 (19/40)	0.0151	0.3850	0.0950	0.931	207.00
30 (1)	0.0098	0.2500	0.0506	0.451	374.00
30 (7/38)	0.0115	0.2930	0.0550	0.519	354.00
30 (19/42)	0.0123	0.3120	0.0720	0.622	310.00
32 (1)	0.0080	0.2030	0.0320	0.289	561.00
32 (7/40)	0.0094	0.2400	0.0350	0.340	597.10
32 (19/44)	0.0100	0.2540	0.0440	0.356	492.00
34 (1)	0.0063	0.1600	0.0201	0.179	951.00
34 (7/42)	0.0083	0.2110	0.0266	0.113	1,491.00
36 (1)	0.0050	0.1270	0.0127	0.072	1,519.00
36 (7/44)	0.0064	0.1630	0.0161	0.130	1,322.00
38 (1)	0.0040	0.1000	0.0078	0.072	2,402.00
40 (1)	0.0031	0.0800	0.0050	0.043	3,878.60
42 (1)	0.0028	0.0700	0.0038	0.028	5,964.00
44 (1)	0.0021	0.0540	0.0023	0.018	8,660.00

## Technical information / definition / terms

**Autoclavability**

See page 46.

**AWG**

See page 48.

**Basis curve**

Metrologically established current carrying capacity curve for connectors according to the measurement procedure described in EN 60512-5-2:2002 depending on the permissible limit temperature of the materials.

**Clearance distance**

The shortest distance, measured as a thread measure, between two live metallic parts in the air.

**Coding**

System of projections and grooves on mating connectors which prevent otherwise identical connectors from being mated. This is useful when several connectors of the same style are used in the same application.

**Connector = ODU SPC**

A component that allows the connection of electrical conductors and that is intended to set up connections with a suitable mating component and/or to separate them. Connectors are operating materials that are not permitted to be inserted or separated when used as intended (when energized). The connector consists of the connector housing and the contact elements.

**Contact resistance**

Total resistance from termination to termination; the contact resistance here is considerably lower than the volume resistance. The information provided refers to average values.

**Creepage distances**

Shortest distance between live parts on the surface of insulators. All elevations and depressions in the insulator are taken into account as far as the specified minimum dimensions are given.

**Crimp area**

The part of a crimp barrel at which the crimp connection is achieved by pressure deformation or by reshaping the barrel around the conductor.

**Crimp barrel**

A hollow part of a contact which accepts one or more conductors and which may be crimped through the application of a crimping tool.

**Crimp connection**

See page 34.

**Current carrying capacity**

(nominal current and max. continuous current)  
The information refers to sufficiently dimensioned connection cables in accordance with DIN VDE 0295 (EN 60228) in Class 5, so that this is not the source of a greater temperature increase. The specified temperature increase takes place through the contact. The information provided refers to average values.

**Derating curve**

The corrected current carrying capacity curve, derived from the established basis curve (0.8 × measured current). It takes into consideration production spreads as well as uncertainties in the temperature measurement and the measurement setup.

**Derating measurement procedure**

(EN 60512-5-2)

Measurement procedure for determining the current carrying capacity of connectors, taking the maximum permissible limit temperature into consideration.

**Fixed connector**

A connector for attachment to a rigid surface (panel).

**Free connector**

A connector for attachment to the free end of a wire or cable. Also called free hanging connector or in-line receptacle.

**Impulse current**

One-time power pulse current with a load period of 10 ms.

**Insertion or withdrawal force**

Force that, without the influence of a coupling or locking device, is required for completely inserting or withdrawing pluggable components.

**Insulator**

Non-conductive part of a connector, for electrically and mechanically separating live parts and for protection against accidental touching.

**Lower limit temperature**

The lowest permissible temperature for operating a connector or plug-in device. For ODU SPC  $-40^{\circ}\text{C}$ .

**Lubrication**

The contacts are pre-lubricated at the factory.

**Materials**

See page 44.

## Technical information / definition / terms

### **Mating cycles**

Mechanical operation of connectors and plug-in devices by insertion and withdrawal. One mating cycle comprises one insertion and one withdrawal

### **Max. continuous current**

The metrologically determined current intensity at room temperature (approx. 20° C [70° F]) that causes the contact temperature to rise to the limit temperature.

### **Nominal single contact current load**

Current load that can load every single contact

### **Nominal voltage**

Nominal voltage characterizes a component.

### **Operating temperature ODU SPC**

-40° C to +140° C (-40° F to 285° F)

### **Operating voltage**

Is the nominal voltage of the current source intended for use with the connector. The operating voltage is not permitted to exceed the connector's nominal voltage.

### **Plug appliance coupler**

Operating materials that are permitted to be inserted or separated during the intended use (when energized or electrically charged).

### **Rated current (IEC 61984)**

The metrologically determined current intensity that leads to an increase of 45 Kelvin in the contact temperature. The current is determined according to the derating measurement procedure (EN 60512-5-2:2002) and is derived from the basis curve.

### **Rated voltage**

Voltage used when rating the connectors and when defining certain operating characteristics.

### **Reference voltage**

The standardized voltage (VDE 0110 or EN 60664-1) for which the insulation of a connector is rated.

### **Solder connection**

Termination technology in which a melted added metal (solder), whose melting temperature is less than that of the base materials to be connected, is used to join two metallic materials.

### **Termination cross-section**

The specified cross-sections correspond to DIN VDE 0295 (EN 60228) Class 5

### **Termination techniques**

Methods for connecting a wire to an electro-mechanical component, e.g., solderless connection according to EN 60352, such as crimp, press-in, etc., or solder contacts.

### **Test voltage**

The voltage that a connector withstands without flashover or arcing under specified conditions.

### **Upper limit temperature**

Highest permissible temperature for operating a connector or plug-in device. This temperature includes the self-heating and the ambient temperature. For ODU SPC 140° C (285° F).

### **Watertightness (EN 60529)**

see page 47.

### **Wire**

Wires may be provided with an insulation cover (electrical shielding). Cables or conductors may consist of one or more wires.

Care must be taken to assure that no person can come in contact with live conductors during installation or operation of the connectors.

ODU reserves the right to change the design and performance of any product to meet changing technical developments without prior notice. ODU reserves the right to discontinue any part in this catalog without prior notice and without obligation to continue production after the change.

## Quality management

ODU has had a powerful quality management system in place for years. ODU has been successfully certified to ISO 9001 since 1994. In addition, the automotive sector of the company group is certified to ISO TS 16949. The certification process was carried out by the internationally active BVQI (Bureau Veritas Quality International) company.

ODU is also certified according the medical norm ISO 13485 : 2003 + AC : 2007.

Additional to this ODU ist approved to different certifications: VDE, UL, UL wiring harness, SCA, VG und MIL.



## The complete ODU product range

<p><b>Single contacts (round or flat)</b></p>			
<p><b>High current connectors</b></p>			
<p><b>Cylindrical connectors with push-pull locking</b></p>			
<p><b>Modular attachable connectors</b></p>			
<p><b>PCB connectors</b></p>			
<p><b>Robust connectors</b></p>			
<p><b>Disposable Systems</b></p>			
<p><b>Custom specific connectors</b></p>			
<p><b>AMC – Advanced Military Connector</b></p>			
<p><b>Cable assembly</b></p>			

## Your partner in all areas

ODU means quality, flexibility and reliability. That's the reason why customers of all areas trust in our products:

- Medical electronics
- Telecommunication
- Industrial electronics and automatisaton
- Measurement and testing
- Engineering and heavy industrie
- Military defence
- Renewable energy.

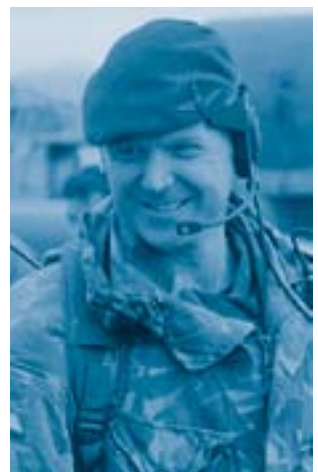

## Please visit our websites!

[www.odu.de](http://www.odu.de)



[www.odu-usa.com](http://www.odu-usa.com)



[www.odu-china.com](http://www.odu-china.com)





**TELEFAX-INQUIRY: +49/08631/6156-49**

ODU Steckverbindingssysteme  
 GmbH & Co. KG  
 Sales ODU SPC  
 Pregelstraße 11  
 84453 Mühldorf a. Inn  
 GERMANY

Company: \_\_\_\_\_  
 Name: \_\_\_\_\_  
 Department: \_\_\_\_\_  
 Street: \_\_\_\_\_  
 City: \_\_\_\_\_  
 Telephone: \_\_\_\_\_  
 E-mail: \_\_\_\_\_  
 Date: \_\_\_\_\_

ODU SPC Summary of technical requirements.

1. Connector application

2. Environment

3. Connector type  Plug  Receptacle  In-Line Receptacle

4. Special version

5. Style

6. Size  1  2  3

7. Coding  1  2  9

8. Colour  Grey  Black  White (on request)

9. Termination  Solder  Crimp  Screw

10. Cross section \_\_\_\_\_ mm<sup>2</sup> \_\_\_\_\_ AWG

11. Cable diameter \_\_\_\_\_ mm

12. Cable bend relief (colour)

13. Protection class acc. DIN EN 60 529  IP 50 (Standard)  IP 67 (watertight)  Other: \_\_\_\_\_

14. Operating temperature \_\_\_\_\_ °C max \_\_\_\_\_ °C min

15. Electrical specifications:

- Operating voltage \_\_\_\_\_ V AC \_\_\_\_\_ V DC

- Operating current Constant: \_\_\_\_\_ A Short-term: \_\_\_\_\_ A/\_\_\_\_\_ Seconds

16. Chemical resistance against

17. Other requirements

18. Autoclaveable  Yes  No

19. Required quantity

20. Production quantity

## The part number key

Nr.	Description	Codierung	1	2	3	4	5	6	7	8	9	10	11	12	13	14	15	16	17	18	19
1	Type	S = Plug G = Receptacle K = In-line receptacle																			
2	Style	1 – 9 and A – Z																			
3	Size	1, 2, 3																			
4	SPC	P																			
5	Coding																				
6	Contact type / surface																				
8	Insulator material																				
9	Colour coding*																				
10	Surface																				
11	Termination																				
12	Type	A																			
13	Termination cross section (2 positions)																				
14																					
16	Collet system (2 positions)																				
17																					
18	Cable bend relief (2 positions)																				
19																					

\* Size 1-3: Colour Coding with cable bend relief

### Example

1	2	3	4	5	6	7	8	9	10	11	12	13	14	15	16	17	18	19
S	1	1	P	2	G	-	U	0	A	C	A	K	0	-	3	7	0	0

- 1 = Plug
- 2 = Style 1 IP 50 with standard back nut
- 3 = Size 1
- 4 = Product Series SPC
- 5 = Coding 2
- 6 = Plastic housing in grey
- 8 = Insulator material PSU/PPSU
- 9 = No colour coding
- 10 = Surface Ag
- 11 = Crimp termination
- 12 = Plastic housing – without EMI protection
- 13/14 = Cross section 4,0 mm<sup>2</sup>
- 16/17 = Collet system for cable diameter > 2.5 – 3.7 mm
- 18/19 = Without cable bend relief

Please open

**ODU worldwide**



**ODU Steckverbindungssysteme GmbH & Co. KG**  
**Otto Dunkel GmbH**  
 Pregelstr. 11  
 84453 Mühldorf a. Inn  
 Germany  
 Phone: +49/8631/6156-0  
 Fax: +49/8631/6156-49  
 E-mail: [zentral@odu.de](mailto:zentral@odu.de)  
 Internet: [www.odu.de](http://www.odu.de)



**ODU France**  
 Phone: +33/1/3935-4690  
 E-mail: [jean-nicolas.vikelas@odu.fr](mailto:jean-nicolas.vikelas@odu.fr)

**ODU Scandinavia**  
 Phone: +46/176/18261  
 E-mail: [peter.biloch@odu.se](mailto:peter.biloch@odu.se)

**ODU UK**  
 Phone: +44/1509-266-433  
 E-mail: [sales@odu-uk.co.uk](mailto:sales@odu-uk.co.uk)

**ODU USA**  
 Phone: +1/805/4840540  
 E-mail: [sales@odu-usa.com](mailto:sales@odu-usa.com)

**ODU Shanghai Trading**  
 Phone: +86/21/58347828-106  
 E-mail: [oduchina@odu.com.cn](mailto:oduchina@odu.com.cn)



Our contribution to environmental protection.